

3D Escher

Escher also worked on regular solids, known as polyhedra, that he extensively explored in many of his works. His woodcut “Three Intersecting Planes” is an especially illuminating example of this.

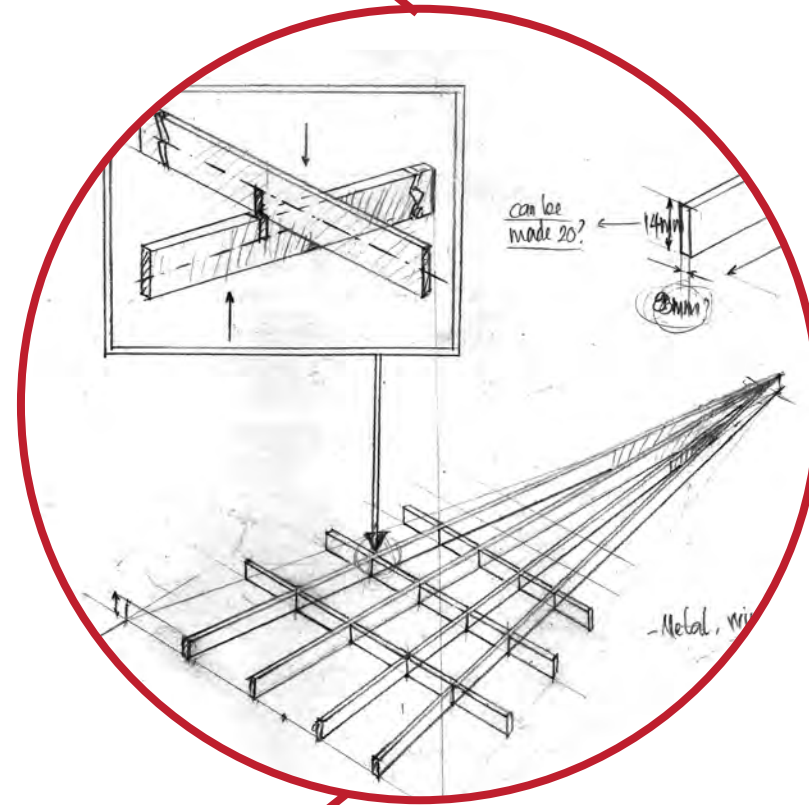

1.5

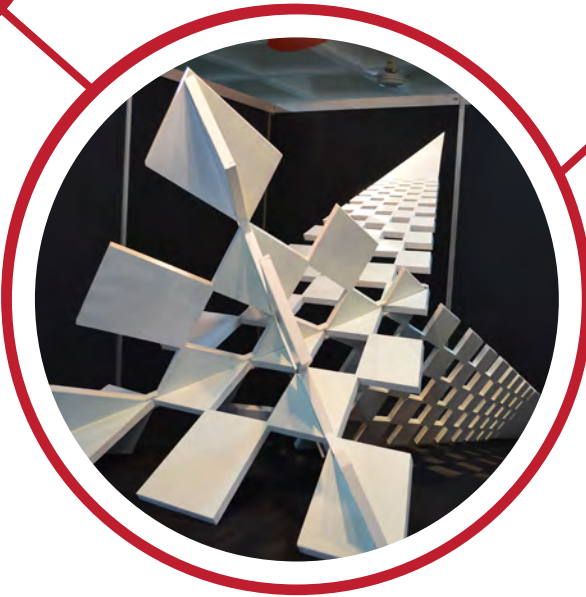

In the present exhibit, the simple fact that two planes meet along an edge and that three planes meet at a vertex is demonstrated in an aesthetically appealing way.

